

Maintenance and Repair Instructions TM 89/03

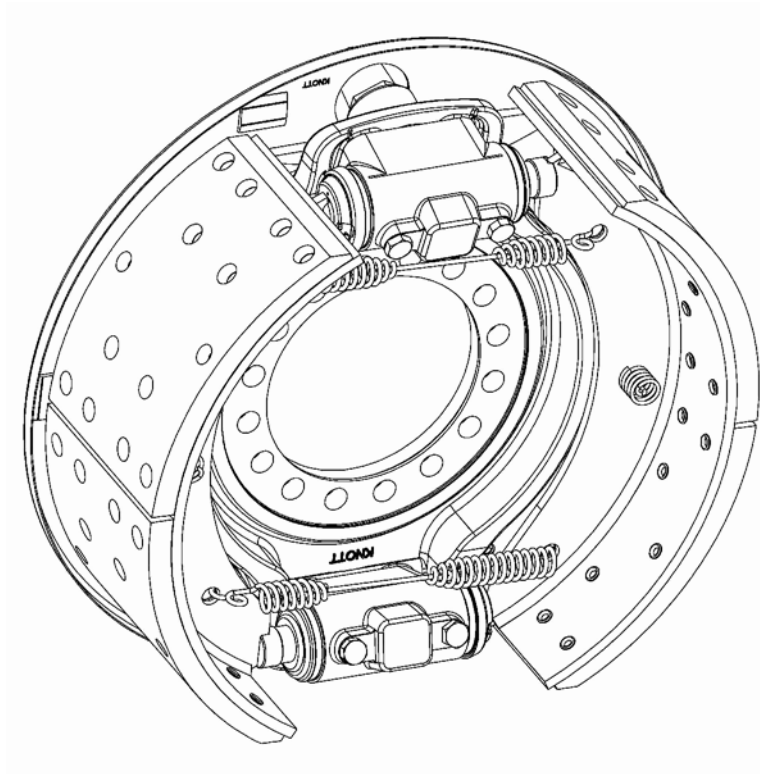

Wedge brake

410 X 180 Simplex

410 X 180 Duplex

500 X 120 Simplex

500 X 160 Simplex

500 X 180 Duplex

The brake described in this manual is subject to development and corresponds to the state-of-the-art at the time of publication.

The manufacturer reserves the right to make changes in engineering, design and specifications or add improvements at any time. Some details of the brakes supplied may therefore vary from the version described.

© Knott GmbH 2006. All rights reserved.

Contents

1	Safety instructions	5
2	Construction and function	6
2.1	General Layout - Simplex Brake	6
2.2	General Layout - Duplex Brake	7
2.3	Operation of the expander mechanism	8
2.4	Automatic self-adjustment mechanism	9
3	Inspecting the brakes	10
3.1	Checking the thickness of the brake linings	10
3.2	Checking the brake shoes and brake linings	10
3.3	Visual inspection of the brake drums	11
3.4	Visual inspection and functional test of the expander mechanism	11
3.5	Other brake parts	11
4	Replacement of wear parts	12
4.1	General safety instructions for maintenance and repair work	12
4.2	Removing and refitting the brake drum	13
	Slackening/tightening the automatic self-adjustment mechanism	13
	Removal of brake drum	14
	Fitting of brake drum	14
4.3	Replacing the brake shoes	15
	Tools and torques	15
	Removing the brake shoes	16
	Fitting the brake shoes (Simplex brake)	17
	Fitting the brake shoes (Duplex brake)	18
4.4	Removing and refitting the expander mechanism	19
4.5	Removing and refitting the expander mechanism	20
	Tools and torques	20
	Removing and refitting the expander mechanism	20
5	Function test and burnishing process	21
	Functional test of the wedge brake	21
	Burnishing of brake linings	21
6	Appendix	22
6.1	Necessary documents, tools and equipment	22
	Notes:	22
	Tools:	22
	Lubricants and operating materials	22

1. Safety instructions

Read these instructions thoroughly before starting work. All information and instructions therein must be strictly observed!

Maintenance and servicing of brakes must be carried out by specially trained personnel!

All applicable accident prevention regulations must be complied with!

Negligence in the execution or failure to carry out maintenance work will render all warranty conditions invalid. In such an event, KNOTT GmbH cannot be held responsible for any damage incurred!



Beware: Danger of injury!

Before commencing maintenance and repair work on the brakes, the vehicle must be secured to prevent it rolling off!



Beware: Danger of injury!

Before commencing work on the brake, ensure that the brake cannot be operated unintentionally!



Caution!

Before starting any assembly work on the actuating cylinders, make sure that there is no actuating pressure and that no actuating pressure can build up while the work is being carried out.

Spring actuating cylinders must be released manually before carrying out maintenance and assembly work!

2. Construction and function

2.1. General Layout - Simplex Brake

Figure 2-1:
**General layout of
simplex brake**

- 1 Expander mechanism
- 2 Brake shoe
- 3 Tension spring
- 4 Brake back plate
- 5 Brake shoe anchor
- 6 Dust shield

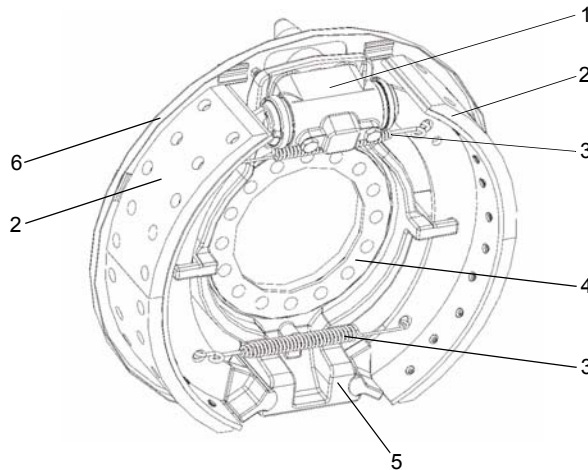

The main components of a simplex brake are the brake back plate, the brake anchor, an expander mechanism, the brake shoes, the dust shield and the tension springs.

The brake shoes are supported by the brake shoe anchor. When the brakes are actuated the expander mechanism pushes the brake shoes against the inside of the brake drum. When the brakes are released the tension springs pull the brake shoes back to their original position.

The dust shield prevents the ingress of water and dust into the brake.

The brake shoe that is pushed away from the expander mechanism during forward motion is the leading shoe. Due to the simplex mechanism the leading shoe is subject to higher wear than the trailing brake shoe.

The braking power is approximately equal in both forward and reverse.

2.2. General Layout - Duplex Brake

Figure 2-2:
General layout of duplex brake

- 1 Spreading mechanism
- 2 Brake shoe
- 3 Tension spring
- 4 Compression spring
- 5 Brake back plate
- 6 Dust shield

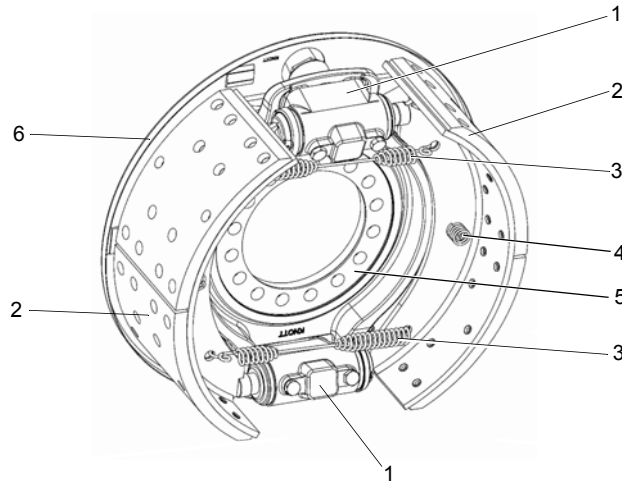

The main components of a duplex brake are the brake back plate, two expander mechanisms, the brake shoes, the dust shield and the tension springs

The brake shoes are held on the back plate by compression springs. When the brakes are actuated the expander mechanisms push the brake shoes against the inside of the brake drum. When the brakes are released the tension springs pull the brake shoes back to their original position.

The dust shield prevents the ingress of water and dust into the brake.

Due to the dual actuation of the brake shoes and the wedge shaped face between the brake shoes and the stud bolts, both shoes act as leading shoes in reverse and forward motion.

As a result the duplex brake has a stronger braking action than the simplex brake. The braking power is approximately equal in both forward and reverse.

2.3. Operation of the expander mechanism

Figure 2-3:
expander mechanism

- 1 Housing
- 2 Wedge
- 3 Stud bolt
- 4 Cup seal
- 5 Pressure roller
- 6 Compression spring
- 7 Self-adjustment mechanism

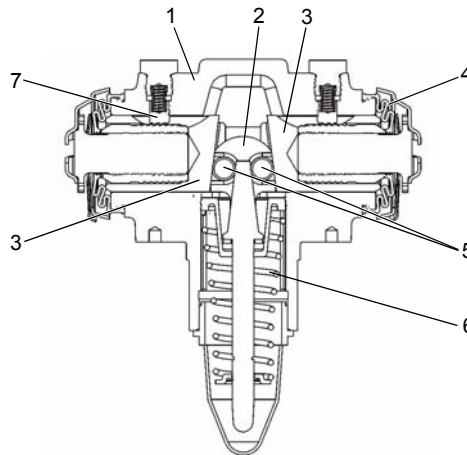

The main components of the expander mechanism are the housing, a wedge, pressure rollers and stud bolts. Cup seals prevent the ingress of dirt and water into the expander mechanism.

Upon brake actuation the wedge is pushed by the actuating cylinder into the expander mechanism. This results in actuation of the stud bolts via the rollers.

Brake shoe wear is compensated by an automatic self-adjustment mechanism. As a result, pedal travel remains roughly the same during the entire service life of the brake shoes.

When the brake is released the compression spring returns the wedge to its original position.

Duplex brakes have one self-adjustment mechanism per expander mechanism, whereas in simplex brakes both stud bolts feature a self-adjustment mechanism.



Note:

For duplex brakes the expander mechanism must be fitted in such a way that the brake shoe is pushed away from the automatic self-adjustment mechanism by the brake drum during forward motion.

2.4. Automatic self-adjustment mechanism

Figure 2-4:
Automatic self-adjustment mechanism

- 1 Stud bolt
- 2 Adjusting plunger
- 3 Adjuster sleeve
- 4 Adjuster bolt with pawl
- 5 Retainer

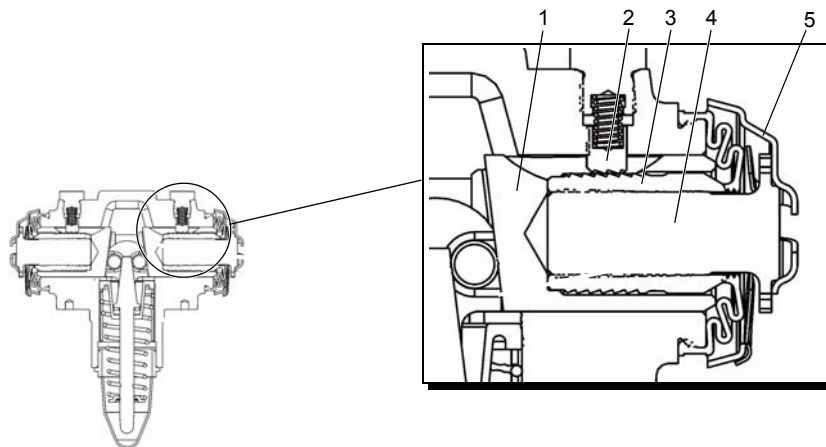

The automatic self-adjustment mechanism is a mechanical actuator between stud bolt and brake shoe. The main components of the self-adjustment mechanism are the adjuster sleeve, the adjuster bolt with pawl, the spring-loaded adjusting plunger and the retainer with leaf spring.

The adjuster sleeve together with the threaded adjuster bolt is located in a blind hole inside the stud bolt. The helical teeth of the adjusting plunger engage with the helical teeth of the adjuster sleeve through an elongated hole in the stud bolt.

When the actuating distance of the stud bolt during braking is longer than the distance between the helical teeth (due to brake lining wear), the spring-loaded adjusting plunger engages with the next tooth of the helical gear of the adjuster sleeve.

When the brake is released, the adjuster sleeve is rotated by one tooth pitch. The spring-loaded retainer prevents the rotation of the adjuster bolt, so that the bolt is unscrewed one turn from the adjuster sleeve in order to compensate for lining wear.

To facilitate removal of the brake drum, the pawl can be used to screw the adjuster bolt back into the adjuster sleeve.

3. Inspecting the brakes



Caution!

Before commencing maintenance and repair work on the brakes, the vehicle must be secured to prevent it rolling off!

Before commencing work on the brake, ensure that the brake cannot be operated unintentionally!

3.1. Checking the thickness of the brake linings

The thickness of the brake linings should be checked visually at intervals according to the amount of use to which the vehicle is put (and no later than every 3 months).

1. Remove the blanking plugs of the dust shield.
2. Check whether the wear edge of the brake linings is still visible.

When the wear edge of the brake linings is no longer visible, the brake linings need to be replaced.

When the lining thickness is approaching the residual lining thickness, the inspection intervals should be shortened accordingly.

3.2. Checking the brake shoes and brake linings

The brake shoes should be checked visually at intervals according to the amount of use to which the vehicle is put (and no later than every 6 months). Remove the brake drums in order to perform this check.



Caution!

Brake linings must only be riveted to the brake shoes by an authorised specialist company! Always use genuine replacement parts!



Note:

The steps for removal and re-fitting of the brake drum are dependent on axle configuration. Consult the corresponding documentation of the axle manufacturer!

The brake linings must be replaced if:

- the wear edge of the brake linings is no longer visible,
- the braking surface is glazed,
- the brake lining has been damaged by heat, or
- the brake linings show surface cracks.



Note:

The brake shoes should be re-conditioned by Knott; state the internal diameter of the braking surface of the drums when placing your order!

Replace the brake shoes if:

- the sliding surfaces on the shoe web are worn or damaged,
- the brake shoes have been damaged by corrosion, or
- the brake shoes are deformed.

3.3. Visual inspection of the brake drums

Check the brake drums for grooving, cracks and wear whenever the brake shoes are changed.



Note:

The wear limits of the brake drums are specified by the axle manufacturer. Consult the documentation provided by the axle manufacturer.

3.4. Visual inspection and functional test of the expander mechanism

Whenever the brake shoes are being replaced, inspect the expander mechanism as follows:

- Visual check for damage of bellows.
Replace the corresponding parts if damage is evident.
- Check that the self-adjusting mechanism turns freely.
If this is not the case, replace the stud bolt of the self-adjustment mechanism.
- Check that the adjuster bolts turn freely.
If this is not the case, replace the expander mechanism.

3.5. Other brake parts

The compression and tension springs and the sealing rings, protective caps and bellows should be replaced at least every 2 years, or earlier if they are worn.



Note:

Always use new tension and compression springs when the brake shoes have been removed for maintenance and repair purposes!

4. Replacement of wear parts

4.1. General safety instructions for maintenance and repair work

The following instructions must be followed when carrying out maintenance and repair work on the brake system.



Beware: Danger of injury!

Before commencing maintenance and repair work on the brakes, the vehicle must be secured to prevent it rolling off!



Beware: Danger of injury!

When working beneath a raised vehicle, the vehicle must be secured on suitable supports to prevent it falling off.

Make absolutely sure that the supports have sufficient load-bearing capacity and are positioned at suitable points on the vehicle!



Beware: Danger of injury!

Before commencing work on the brake, ensure that the brake cannot be operated unintentionally!



Caution!

Parts subject to wear must be replaced axle by axle!



Caution!

Brake linings must only be riveted to the brake shoes by an authorised specialist company! Always use genuine replacement parts!



Caution!

If the brakes are actuated via a spring actuation cylinder, use the emergency release device to prevent accidental actuation of the brakes!

4.2. Removing and refitting the brake drum

Slackening/tightening the automatic self-adjustment mechanism



Caution!

After fitting the brake drum the brake must be adjusted using the self-adjusting mechanism! If the automatic adjusting mechanism is left in its bottom position, the brake will not automatically adjust itself.



Note:

Each wedge brake has two automatic self-adjusting mechanisms:

- Simplex brake: at Pos. 1 and 2
- Duplex brake, left hand side of vehicle: at Pos. 2 and 3
- Duplex brake, right hand side of vehicle: at Pos. 1 and 4

Figure 4-1:
Rear of wedge brake
(drawing)

- 1 expander mechanism
- 2 Dust shield

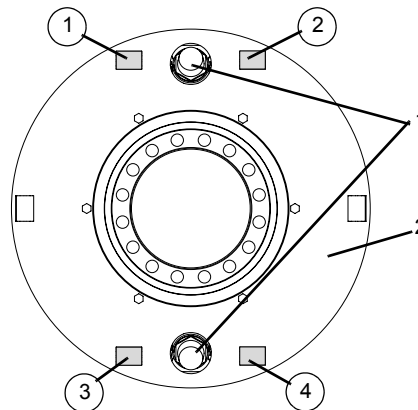

1. Remove the blanking plugs of the dust shield.
2. Use a screwdriver inserted into the dust shield hole to rotate the self-adjustment mechanism in reverse direction.

Item	Adjustment direction	Effect on brake
1	upwards	Tighten brake
	downwards	Release brake
2	upwards	Release brake
	downwards	Tighten brake
3	upwards	Tighten brake
	downwards	Release brake
4	upwards	Release brake
	downwards	Tighten brake

Tab. 4.1 Effect of adjusting the pawl (via the adjustment hole at the rear of the brake)

Removal of brake drum

1. Undo the automatic self-adjustment mechanisms. See “Slackening/tightening the automatic self-adjustment mechanism” on page 13.



Note:

The steps for fitting and removal of the brake drum are dependent on axle construction. Consult the corresponding documentation of the axle manufacturer!

2. Remove the brake drum from the brake assembly.

Fitting of brake drum



Caution!

Follow the instructions for burnishing if you are using new brake linings and/or brake drums. See “Burnishing of brake linings” on page 21.



Note:

The allowable limits for damage and wear of the brake drum are dependent on axle construction! Consult the corresponding documentation of the axle manufacturer! If scoring can be seen on the braking surfaces of the brake drum, these will have to be machined in accordance with the specifications of the axle manufacturer.

The steps for fitting and removal of the brake drum are dependent on axle construction. Consult the corresponding documentation of the axle manufacturer.

1. Using a suitable tool thread the adjuster bolts of both self-adjustment mechanism to the bottom of the adjuster sleeve and then back it out by approx. 1 turn.
2. Remove all dirt and rust from the brake drum and the brake linings.
3. Check brake tension and compression springs for obvious damage. Damaged components must be replaced.
4. Check the brake drum for cracks and scoring.
5. Remove any protrusions of the inside of the braking surface with a suitable tool when refitting the brake drum.
6. Fit the brake drum. Consult the fitting instructions of the axle manufacturer!
7. Using a suitable tool turn the adjustment bolt of the self-adjustment mechanism until the drum can no longer be rotated by hand. See “Slackening/tightening the automatic self-adjustment mechanism” on page 13..
8. Slacken the self-adjustment mechanism 3 - 4 teeth until the brake drum can be rotated again.
9. Repeat this procedure for the second self-adjustment mechanism.

4.3. Replacing the brake shoes



Caution!

Follow the instructions for burnishing if you are using new brake linings and/or brake drums. See “Burnishing of brake linings” on page 21.



Note:

When using new brake linings, these must be matched to the internal dimension of the brake drum! Always specify the internal dimension of the braking surface of the drum when ordering brake shoes!



Note:

If the original brake drums are being reused, the brake lining edges can be chamfered to 45° with a file in order to facilitate re-assembly!



Note:

Remove any dirt from the brake linings, such as greasy fingerprints, using emery cloth or an abrasive pad.

Tools and torques

Necessary tools and torques:

Item. no..	Designation	Description	M (Nm)
	Spring pliers		
	Spring compressor		

Removing the brake shoes



Beware: Danger of injury!

Risk of injury from the pre-stressed tension springs. When removing the brake shoes, there is a risk of injury due to the tension springs snapping back. Use spring pliers to detach the tension springs.

Figure 4-2:
Removing the brake shoes

- 1 Duplex brake
- 2 Simplex brake
- 3 Tension spring
- 4 Compression spring
- 5 Brake shoes
- 6 Brake shoe anchor

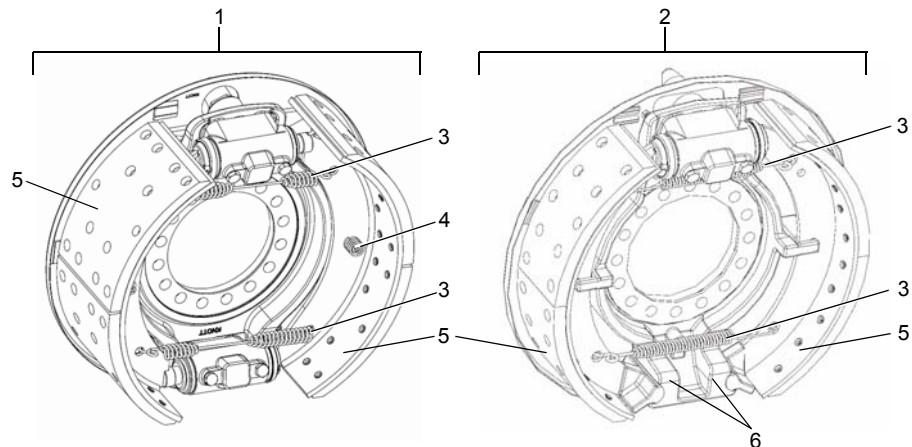

1. Remove the brake drum. See “Slackening/tightening the automatic self-adjustment mechanism” on page 13.
2. Using spring pliers, release [unhook] the tension springs.

For simple brakes

3. Remove the brake shoes and check the grooved pins in the brake shoe anchor for damage.

For duplex brakes

3. Unhook the compression springs using a spring compressor.
4. Remove the brake shoes.
5. Check all components for damage and wear.

Fitting the brake shoes (Simplex brake)



Beware: Danger of injury!

Risk of injury when attaching the tension springs. When fitting the brake shoes, there is a risk of injury due to the tension springs snapping back. Use spring pliers to attach the tension springs.

Figure 4-3:
Fitting the brake shoes - Simplex brake

- 1 Self-adjustment mechanism
- 2 Brake shoe
- 3 Adjuster bolt
- 4 Tension spring
- 5 Brake shoe anchor
- 6 Grooved pin



1. Using a suitable tool thread the adjuster bolts of both self-adjustment mechanism to the bottom of the adjuster sleeve and then back it out by approx. 1 turn.
2. Lightly grease the adjuster bolt and the face of the brake anchor using copper grease.
3. Check the grooved pin of the brake anchor for damage and make sure that it is fully inserted into the brake anchor.
4. Attach the brake shoes to the brake anchor.
5. Refit the tension springs to the brake shoes.
6. Fit the brake drums. See "Fitting of brake drum" on page 14.

Fitting the brake shoes (Duplex brake)



Beware: Danger of injury!

Risk of injury when attaching the tension springs. When fitting the brake shoes, there is a risk of injury due to the tension springs snapping back. Use spring pliers to attach the tension springs.

Figure 4-4:
Replacing the brake linings

- 1 Adjuster bolt
- 2 Stud bolt bearing surface
- 3 Brake shoes
- 4 Compression spring
- 5 Tension spring
- 6 Brake anchor plate

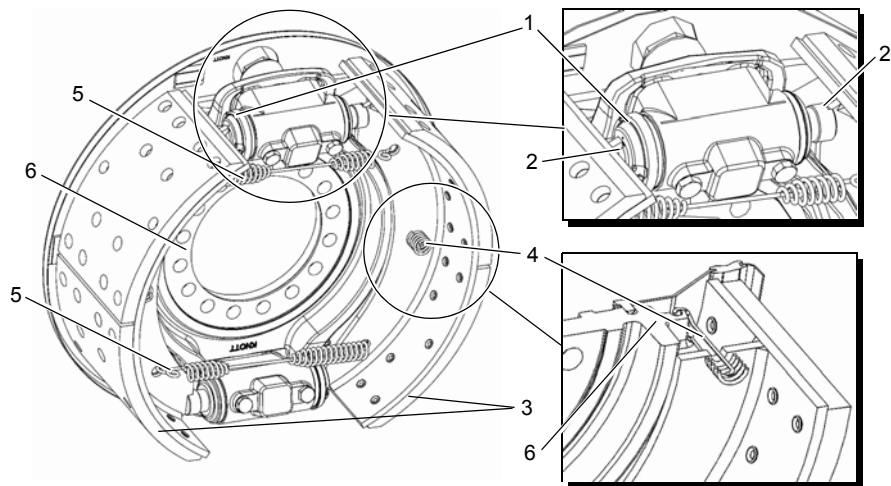

1. Using a suitable tool thread the adjuster bolts of both self-adjustment mechanism to the bottom of the adjuster sleeve and then back it out by approx. 1 turn.
2. Ensure that the raised side of the ramp shaped face of the stud bolts is pointing towards the outside.
3. Grease the stud bolts and those areas where the brake shoes come into contact with the anchor plate using copper grease.



Caution!

The arrow on the brake shoe web plate must point in the direction of forward travel (rotational direction of the brake drum)!

4. Insert the brake shoes in the stud bolts.
5. Hook the compressions springs through the brake shoe holes into the brake shoe web.



Note:

Make sure that the bent ends of the compression springs are hooked into the indentations on the rear of the brake back plate.

6. Refit the tension springs to the brake shoes.
7. Fit the brake drums. See "Fitting of brake drum" on page 14.

4.4. Removing and refitting the expander mechanism

Removing and refitting the expander mechanism



Beware: Danger of injury!

Before commencing work on the brake, ensure that the brake cannot be operated unintentionally!



Caution!

If the brakes are actuated via a spring actuation cylinder, use the emergency release device to prevent accidental actuation of the brakes!

Figure 4-5:
Removing and refitting the expander mechanism

- 1 Wedge
- 2 Compression spring
- 3 Boot
- 4 Pressure roller
- 5 Stud bolt

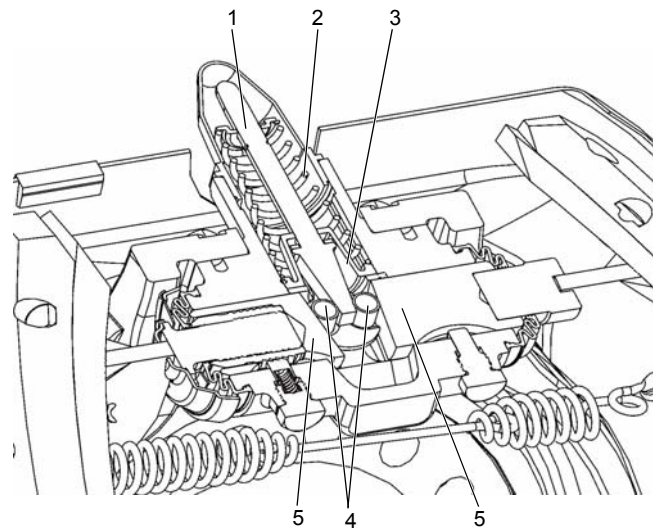

1. Remove the actuating cylinder from the expander mechanism (see TM 98/05).
2. Pull the wedge from the expander mechanism.



Note:

Ensure that you remove the boot, the compression spring and both actuating rollers together with the wedge!



Caution!

It must be possible to insert the wedge into the expander mechanism until the boot is flush against the housing of the expander mechanism without using force!

3. Refitting is the reverse sequence to removal; ensure that the thrust rollers are pointing in the direction of the stud bolts.



Note:

Grease the wedge and the thrust rollers using standard high pressure universal grease.

4.5. Removing and refitting the expander mechanism

Tools and torques

Required tools and torques:

Item. no..	Designation	Description	M (Nm)
3	Ring spanner	WAF 19	195 - 225

Removing and refitting the expander mechanism



Beware: Danger of injury!

Before commencing work on the brake, ensure that the brake cannot be operated unintentionally!



Caution!

If the brakes are actuated via a spring actuation cylinder, use the emergency release device to prevent accidental actuation of the brakes!

Figure 4-6:
Removing and refitting the expander mechanism

- 1 expander mechanism
- 2 Brake back plate
- 3 Assembly bolt

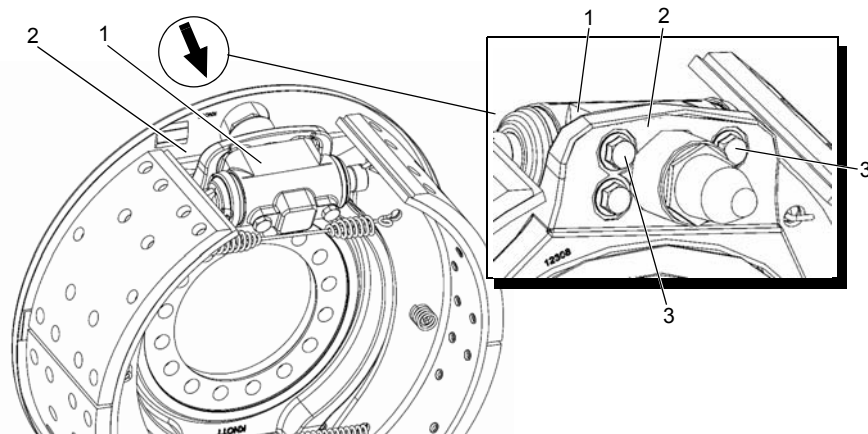

1. Remove the brake drum. See "Slackening/tightening the automatic self-adjustment mechanism" on page 13.
2. Remove the brake shoes. See "Removing the brake shoes" on page 16.
3. Remove the actuating cylinder from the expander mechanism (see TM 98/05).
4. Unscrew the assembly bolts of the expander mechanism.
5. Remove the expander mechanism from the brake back plate.
6. Reverse the above sequence to fit.

5. Function test and burnishing process

Functional test of the wedge brake

The wedge brake function should only be tested on a rolling road dynamometer.

Burnishing of brake linings



Beware: Danger of injury!

Risk of accident when applying the brakes on public roads. The brakes should be burnished by applying the brakes continuously on a rolling road dynamometer.

If the brakes are burnished on public roads, particular attention should be paid to traffic behind the vehicle in order to avoid rear-end collisions.

To allow new brake linings to achieve maximum braking power, the brake must be burnished after the brake linings are changed.

Burnishing by continuous braking

- Bed in the brake on the dynamometer or while driving by applying light braking pressure.
- Release the brake several times while bedding in to allow the binder in the linings to outgas.
- The temperature of the brake drum should not exceed 250° C in this way.
- Once the brakes have cooled down, test the braking power that can be achieved, and repeat the burnishing process until the prescribed braking power is achieved.

Burnishing by stop braking



Caution!

Avoid braking sharply with strong deceleration during the burnishing process.

- Carry out stop brakings with medium pressure and medium speed unless a brake drum temperature of approx. 250° C is achieved.
- Once the brakes have cooled down, test the braking power that can be achieved, and repeat the burnishing process until the prescribed braking power is achieved.

6. Appendix

6.1. Necessary documents, tools and equipment

Notes:

- Maintenance and Repair Instructions TM 89/03
- Fitting instructions TM 98/05

Tools:

- The usual workshop tools are required for fitting and dismantling work.
- Special tools
We also recommend the use of the following tools and equipment, which can be ordered by article number from the KNOTT spare parts service.

Designation	Art. no. or specification
Spring pliers	
Spring compressor	

Lubricants and operating materials

Lubricant or service material	Type or designation
Mineral oil based grease, Lithium grease, EP, NLG2	e.g. Fuchs Renolit Duraplex EP2
Copper grease	
Abrasive pad, emery cloth	Grit 120